

The AWE Wall: A Smart Reconfigurable Robotic Surface

M. Kwoka*, J. Johnson**, H. Houayek***, I. Dunlap***, I. D. Walker*, and K. E. Green***

All authors are from Clemson University, South Carolina 29634, USA.

Department of *Electrical and Computer Engineering **Mechanical Engineering ***Architecture
mkwoka, joseph7, hde, isaiahd, iwalker, kegreen @clemson.edu

Keywords: robotics, animation, human-robotic interaction, intelligent environments

Abstract

In this paper, we introduce a new robot “wall” surface, featuring a multiple folding panel structure. The wall forms part of AWE, a novel “Animated Work Environment”, which seeks to introduce robotics at the architectural scale to modify environments in real time to the changing needs and moods of their occupants. The panels of the AWE wall will feature embedded IT and adapt to the current movements and tasks of the user. We describe the overall AWE concept and detail the design and construction of the robot surface. Motion planning and control issues are discussed.

1 Introduction

Robotic systems are being deployed in places also occupied by people, increasingly often in close contact with the human inhabitants. Robotic technologies are generally deployed within existing architectural environments (factories, offices, homes, etc.). Mitchell [9] believes that in the near future “our buildings will become ... robots for living in”. However, robots enter the existing architecture, but that architecture itself typically remains static and untouched by robotics. Indeed, the term “robot architecture” is synonymous within the field with the local organization of subsystems within a robot, rather than being associated with the surrounding built environment, the usual (conversational) sense of the word architecture. In this paper, we describe the early results of an effort to expand the impact of robotics to the (larger) architectural scale. In particular we focus on novel “robot architecture” (at the scale of a wall) in the context of the work environment, an area into which technology has encroached significantly, but in which the underpinning architectural firmament has remained largely static.

Typical workstations today (whether in the office or at home) consist fundamentally of a desk and a chair coupled with a computer and its peripherals. In a world of ever advancing information and automation technologies (IT), the utility of this concept seems outdated. Today’s workstation environment has not replaced paper with

digital documents. Management and display of information remains a problem [17]. There is difficulty when comparing digital information with printed information [2], [8]. Problems arise when several people collaborate at a workstation [1] because typically they can not all see the important information clearly. Today’s workstation environment space is simply not well-designed for collaboration. Hence, many office environments have completely separate rooms or spaces that go unused for much of the work week. Having a presentation or group meeting within the workstation environment is usually impractical because of the cramped and inflexible surrounding environment.

Therefore, there is a strong motivation for the creation of workstation spaces that can adapt in real time to the changing needs and moods of their occupants. In particular, a workstation that could “move aside” to enable group meetings and presentations, but also “close in” to form a more intimate space for individual work, while adapting to the particular needs of each new situation, could much better utilize available space resources. This concept helps motivate our research in robotically enhanced spaces.

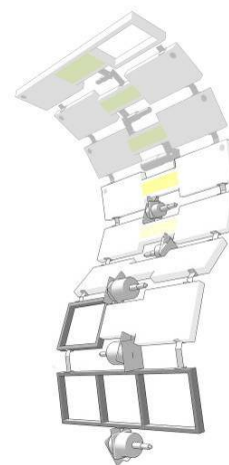

Figure 1: AWE wall concept

AWE, (Animated Work Environment), is an ongoing

project in “Animated Architecture” by a multidisciplinary group, including the authors, at Clemson University [4]. The key idea behind this project is to create an environment that conforms to the users need rather than having an inflexible physical environment that the user must adapt to [4], [11]. AWE is meant to facilitate individual work, collaborative work (including the facilitation of presentations to a group), and to even allow for gaming. A key component of AWE is the robotic “wall” element introduced in this paper. The AWE wall (see figure 1) is a novel robotic surface that reconfigures according to the user’s needs. This ability allows the system to reconfigure as a wall when not in use, and adjust for numerous tasks such as presentations and group collaboration, while adapting to users individual situations (conforming to the shape/size most comfortable for unusually sized users, wheelchair bound users, etc.).

2 AWE design and implementation

The AWE wall design is a foldable surface comprised of eight surfaces (panels) that are hinged, with the hinges actuated by electric motors (see figure 1). The motors are geared down via harmonic drives to enable the high torque loads of the worst case scenarios this system needs to handle [7]. The eight degree of freedom wall is kinematically redundant for tasks of seven or less degrees of freedom (this is the case for all envisioned tasks for the wall at this time). The system is therefore a novel (unique to the best of our knowledge) realization of a kinematically redundant surface.

The design additionally includes the provision for vertical grooved rails that any of the panels can (optionally) slot into on either side of the panel tip, via dual retractable pins mounted at the panel tip (see Figure 2).

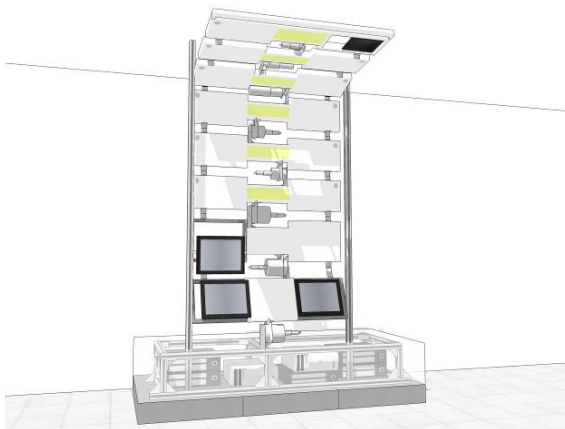

Figure 2: The AWE wall showing side rails. (This particular configuration is an example of collaborative composing).

When thus connected to the rails, a panel will be free to slide in the vertical direction of the rail. This feature is designed to provide increased stability in the horizontal direction, while minimally limiting motion. This will also

enable the wall to reconfigure its kinematic structure within a novel family of constrained redundant systems. This makes the modeling and motion planning for the AWE wall (see section III) of particular interest. First, in the following, we describe the context for the operation of the wall.

The robotic wall will be integrated into the overall AWE environment (see figure 2). It will be integrated with a modular “smart desk”, which will house some peripherals, while being designed to easily fold away to create a larger open space. Note that our work is not focused on robotic furniture [3] as such, more on intelligent environments [6], [14], [15]. The wall will have a number of “basic” configurations, matched to particular tasks (see figures 2-7). Users will be able to adjust the wall about these basic configurations using either proximity sensors or a Graphical User Interface (GUI).

The AWE wall features multiple displays [12], [16] in order to facilitate more productive individual and collaborative activity. The bottom two panels, the ones closest to the floor, house three monitors (See figures 2-7). The bottom panel features two 19 inch standard screens. The second panel features one additional 19 inch monitor to allow the users even more flexibility with their computing. The monitors can be adjusted (manually) to slide together (vertically for the left hand pair, or horizontally for the lower pair), and rotate inwards (see Figure 3).

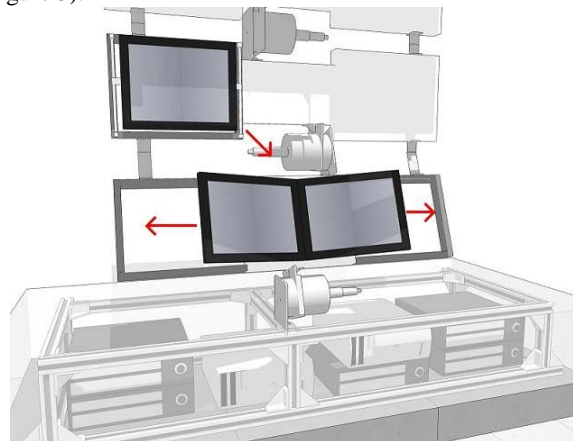

Figure 3: Design for the bottom panels of AWE. Bottom two screens can rotate and slide, top screen can slide.

This facilitates a single user working between multiple tasks, or working on one task with many digital sources. It is also advantageous for at least two reasons in collaboration mode. First, it allows the user the option of placing up to three documents in separate screens. Second, it provides the ability to have the same document in three different screens; in this case, the user might choose to configure the monitors so that the group could view the document without being in the way of other viewers. This makes collaboration easier because everyone can simultaneously view the same document, or up to three

documents may be simultaneously viewed and discussed. We anticipate that users will find a variety of ways to adapt the screens, in conjunction with configuring the wall.

The panel faces not otherwise equipped will be covered with Alucobond, a lightweight surface that has been used for covering buildings. This surface can double as a whiteboard for jotting down notes for users. This feature is especially desired by our collaborators concentrating on human factors, who are particularly concerned with AWE's ability to facilitate work with mixed media materials. Numerous additional peripherals (for example cameras, proximity sensors, and lighting) will be integrated into the upper panels. Lighting will be particularly important in presentation mode (see figure 4), when gaming (see figure 5), and when needing more privacy, but still wanting a lot of light (see figure 6). The second to top section will contain a smaller screen to use for a second user working on a different task (see figures 5 and 7).



Figure 6: Privacy mode

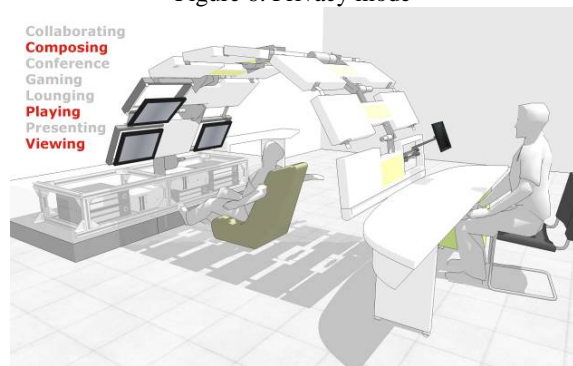

Figure 7: Multi-user mode

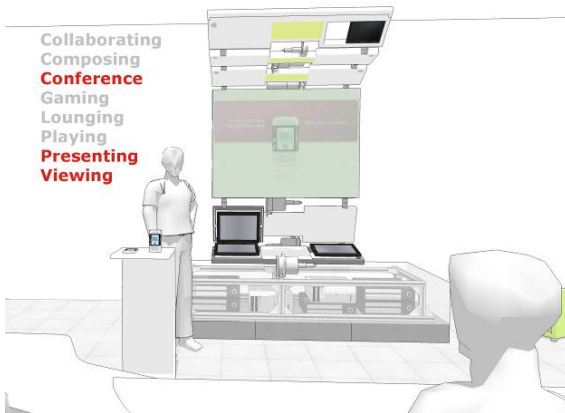

Figure 4: Presentation mode

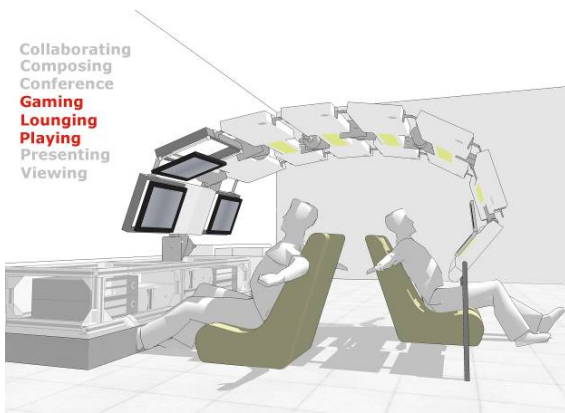

Figure 5: Gaming mode

The design process and initial construction of the AWE wall are described in [7]. Currently five of the eight sections are operational in a physical prototype (see Figure 8). Since the initial work reported in [7], two additional panels have been integrated, and the low-level controller has been developed and validated. The current focus (detailed in the following sections) is on the motion and trajectory planning for the system.



Figure 8: Current prototype

3 Redundancy Resolution

A. Trajectory Planning

For real-time motion planning of AWE, we adopt the resolved rate approach [10], [13] based on a conventional Jacobian-based model

$$\dot{\mathbf{x}} = [J(\mathbf{q})]\dot{\mathbf{q}} \quad (1)$$

where \mathbf{q} is the 8×1 vector of joint (panel) angles, $\dot{\mathbf{q}}$ their time velocity, $\dot{\mathbf{x}}$ is a (given) $m \times 1$ task space velocity (\mathbf{x} defined variously for different AWE modes of operation, as discussed below), and $[J]$ is the corresponding AWE Jacobian.

The key novelty of the AWE redundancy resolution problem is in the nature of the task spaces and tasks required of the “robot-wall” (i.e. $(\mathbf{x}, \dot{\mathbf{x}})$) rather than the structure of $[J]$. Note that for the current AWE hardware implementation, the unconstrained structure behaves kinematically as a planar serial rigid-link mechanism. Therefore elements of the rows of $[J]$ corresponding to the task space of the k^{th} panel $\mathbf{x}_k = [x_k, y_k, \phi_k]^T$ are easily established as

$$\begin{aligned} J_{1i}(\mathbf{q}) &= -\sum_{j=1}^{k-i+1} a_j \sin\left(\sum_{k=1}^j q_k\right) \\ J_{2i}(\mathbf{q}) &= \sum_{j=1}^{k-i+1} a_j \cos\left(\sum_{k=1}^j q_k\right) \\ J_{3i}(\mathbf{q}) &= 1 \\ (i &= 1, \dots, k) \end{aligned}$$

In the above, the variables (x_k, y_k) are the coordinates of the tip of the k^{th} panel, in a coordinate frame (fixed at the base of the AWE wall) having its z axis aligned with the panels, and its y axis vertical. The variable ϕ_k represents the orientation of the k^{th} AWE panel (defined in the (x, y) plane perpendicular to the AWE panels, and measured counterclockwise from the horizontal x axis of the above fixed frame). The parameter a_j is the known side height (vertical dimension) of the j^{th} AWE panel.

Therefore the Jacobian elements corresponding to tasks described in any of the AWE panel coordinates \mathbf{x}_k are readily available and easily computable. The key issue is how to exploit this information to achieve the desired motion of AWE for its various tasks.

An unusual aspect of the AWE application is that

complete regulation of the “end effector” (tip of the AWE wall) position/orientation is rarely the primary consideration. More typically, positioning/orienting of screens more proximal to the base represents the primary task, and only orientation of the tip (to, for example, direct lighting on to screens or users) is of primary concern at the tip. Positioning of the final (and other) panel(s) therefore becomes a subtask in the redundancy resolution. This is in contrast to the usual serial-link redundancy resolution problem in the literature, where the end effector (tip) task is primary, and the body motion secondary, to the problem. An additional novel feature of AWE is the ability of the panels to connect to the side rails, and slide vertically. This allows the system to reconfigure into a large number of partially constrained (but still kinematically redundant) systems.

To encode these requirements in a consistent form, and to include other task constraints (such as use of the vertical tracks discussed in section II) the task space vector \mathbf{x} in (1) is selected as (the non-zero elements of)

$$\mathbf{x} = [S]\tilde{\mathbf{x}}$$

where $\tilde{\mathbf{x}} = [\mathbf{x}_1, \dots, \mathbf{x}_8]$ and the (24×24) matrix $[S] = \text{diag}(s_i)$. The Task Selection matrix $[S]$ encodes the different modes of AWE operation and transitions between them. A non-zero element s_i in $[S]$ indicates a specific primary task requirement for the corresponding element of $\tilde{\mathbf{x}}$ in the current AWE mode. For example, for the “Presentation” mode (figure 4) the non-zero elements of $[S]$ will include $\{s_4, s_5\}$ (representing tip position of panel 2, the “base” of the screen), and $\{s_9, s_{12}, s_{15}\}$ (representing the orientation constraints on panels $\{3, 4, 5\}$, required to keep the screen vertical). For modes incorporating the vertical rails, the corresponding non-zero elements of $[S]$ will fall in the set $\{s_1, s_4, s_7, \dots, s_{19}, s_{22}\}$ (representing the constraints on the horizontal (x) directional motion of the panels pinned by the rails). Transitions between AWE modes are accommodated by smooth (time) trajectories of the s_i , to and around zero. Note that this enables smooth transition between the structural changes in (1) required as the task space of AWE changes between modes.

Given a selection of \mathbf{x} as above, real-time trajectory planning is achieved via iteratively updating the nominal panel joint velocities $\dot{\mathbf{q}}$ (and hence the controlled input positions \mathbf{q} via numerical integration) in (1) based on the iterative algorithm

$$\dot{\mathbf{q}} = [J(\mathbf{q})]^+ \dot{\mathbf{x}} + [I - J^+ J]\boldsymbol{\varepsilon} \quad (2)$$

where $[J]^+$ is a (right-sided) generalized inverse of $[J]$ (for example $[J]^+ = [J]^T ([J][J]^T)^{-1}$, the Moore-Penrose inverse), and the 8×1 vector $\boldsymbol{\epsilon}$ is arbitrary, to be selected according to the particular redundancy resolution scheme adopted (see below). The vector $\boldsymbol{\epsilon}$ tunes the “self-motion” term $[I - J^+J]\boldsymbol{\epsilon}$ which exploits the redundant degrees of freedom for subtask performance after satisfying the primary task given by $\dot{\mathbf{x}}$ [10], [13].

The above redundancy resolution scheme for AWE affords a number of alternative implementations. Ultimately, we envision the task space input $\dot{\mathbf{x}}$ to be largely directly input by the user(s) via proximity sensors (desired motion orthogonal to panel with sensor, speed proportional to proximity of users closest body part). We also plan to experiment with alternative input devices such as joysticks and Wii input devices. However, at the present time we generate the task space velocities via simulation (see next section), and send the resulting joint variable information to the controller in real time. For the subtask performance (i.e. selection of $\boldsymbol{\epsilon}$) numerous approaches have been established in the literature [10], [13]. Currently, for the five-panel version of AWE in operation, we adopt the gradient projection approach introduced by Yoshikawa [18] to configure AWE closest to a pre-assigned desired configuration, subject to satisfying the primary task constraints. See the discussion in the following section.

B. Control

Each panel is controlled with an independent PID controller. The control computations are performed in real time using a Pentium PC, with I/O achieved via a commercial *ServoToGo* interface board. The input signals are amplified by commercial Techron amplifiers (details). The overall control structure is shown in Figure 9.

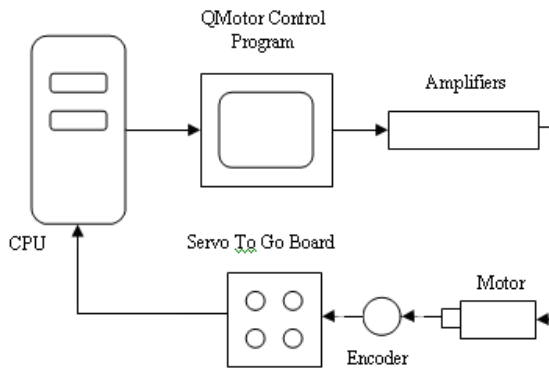

Figure 9: System control structure

The controllers are implemented on a PC with an Intel Pentium 4 Processor, operating at 2.86Hz, running QNX 3.2.1 real-time operating system. In this environment,

QMotor 3.22 allows the user to achieve real-time control response [7]. Given the relatively slow speeds, tuning of the controller for each panel was straightforward. The control algorithm was written in C++. The user can also perform tasks such as data logging and online gain tuning was performed using Qmotor. The software also allows the user to easily swap between different control modes.

4 Simulation Experiments

In this section, we present the results of simulations of the motion planning approach outlined above. One of the novel aspects of the AWE wall is the class of tasks required of it in the intelligent workspace environment. In particular, unlike most previous applications of kinematically redundant systems, the primary task is not usually specified by motion of the most distal (“end effector”) element. For this application, typically the primary task is more proximal to the base, and the tip motion forms part of secondary tasks. This makes the motion planning particularly interesting.

For example, one envisioned mode for the Animated Work Environment is presentation. A screen attachment will be unfolded from an upper panel to provide the background for the presentation images (see figure 4). A light from the top of the AWE wall may be desired to highlight an object the speaker is talking about, or it may highlight the speaker. None if this is in itself particularly novel, and can be achieved in a typical presentation environment. However, what if the speaker begins to pace? They may remove themselves from the light. People may not be able to see them as well. Their typical presentation environment remains essentially static.

The AWE wall, as a robotic workstation, can adapt to the user. It will follow the speaker (guided by information from its sensors), maintaining its relative orientation and continuing to optimally illuminate them. Note that in this mode, the wall must not only hold the lighting on the speaker, but also hold the screen in its orientation so that the audience may pay attention to what has been written as well. We provide an example of this behavior in the simulation results below.

For these simulations we used the Jacobian pseudoinverse-based model (2). Different versions of the Jacobian corresponding to different modes for the wall, as discussed in the previous section, were selected for the different experiments. The simulation, written in C++, includes the hardware joint limit constraints and singularity checking.

The first experiment shown here has 4 panels constrained, corresponding to the presentation mode discussed above (figure 4). If we number the panels from the bottom up 1 through 8, panels 3, 4, 5, and 8 are all (partially) constrained. Panels 3, 4, and 5 need to maintain their orientation – but not position – to maintain the screen orientation, and panel 8 must retain its relative orientation to maintain the lighting task. This leaves panels 1, 2, 6, and 7, and the remaining degrees of

freedom of panels 3, 4, 5, and 8 free to move around while holding the other panels in their original orientation. The constrained elements in the task space (with corresponding rows included in the Jacobian in (2), and components of $\dot{\mathbf{x}}$ set to zero in (2)) are the third elements of $\{\mathbf{x}_3, \mathbf{x}_4, \mathbf{x}_5, \mathbf{x}_8\}$. Thus the overall task is four-dimensional, resulting in a degree of redundancy of four in the eight degree of freedom wall.

The results of this experiment have been exported to Rhino 3D, a modeling program, and are shown in figure 10. Two motions are shown, corresponding to two desired orientations of the screen. The straight segment is centrally located and the wall is adjusting to the simulated movements of the speaker, regulating the movement of the top panel. It can be seen that the middle panels (3, 4, and 5) successfully maintain their posture to support and orient the screen, while the final panel maintains its orientation while moving with the speaker.

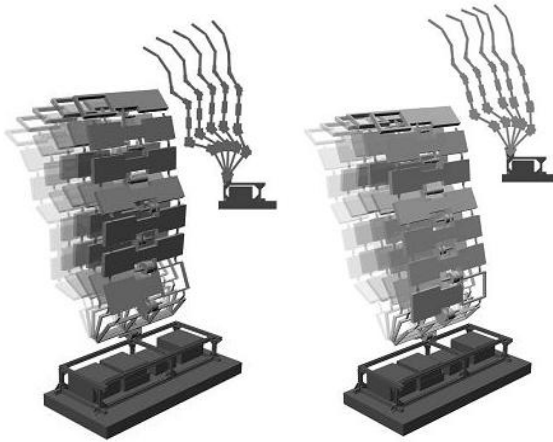

Figure 10: Presentation mode motions

The second experiment shows motion planning for the system in “rail” mode. In this example the tip of panel 5 is modeled as inserted to the rail, thus constraining its motion to the vertical. Therefore the Jacobian for this example contains the (first) row corresponding to the panel 5 task space \mathbf{x}_5 , with the corresponding element of $\dot{\mathbf{x}}$ commanded to zero (to constrain tip 5 movement in the x direction) in the simulation.

The results of this experiment are shown in figure 11. It can be seen that the self-motion of the redundant joints adjusts the trajectory to allow the tip of the 5th panel to slide vertically while maintaining the horizontal constraint.

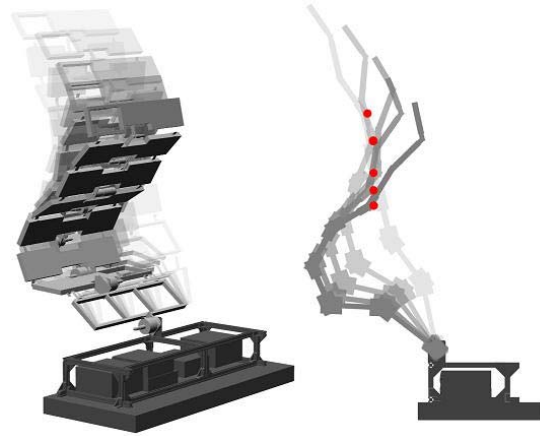

Figure 11: Rail constraint motion

The final experiment reported here is that of motion between modes. The robotic wall can assume many possible configuration histories, due to the inherent self motion, we have explored the notion of different *guiding* configurations to improve path choice from one preassigned desired configuration to another. Eight different guiding configurations, along with the preset modes, were selected, to investigate uses for self motion in this application. These guiding configurations were biologically inspired by the cobra, sequoia ostrich, an elephant’s trunk, and the shape of a football to reflect the perceived “organic” nature of the wall. All but the sequoia and elephant’s trunk were mirrored over the y plane to create a second new guiding configuration in each case.



Figures 12 and 13: snake and ostrich guiding configurations



Figures 14 and 15: Elephant and Sequoia guiding configurations



Figure 16: Football guiding configuration

Recall that the function of a guiding configuration is used to resolve the redundancy by providing a “guide” for the wall to be “closest to” during a given movement under the motion planning strategy in (2). So the wall in some sense is expected to exhibit the “nature” of the selected guiding configuration during the motion. To explore this concept for each guiding configuration, the motion was tested to and from each of the base configurations, some of which can be seen in figures 4 through 7. The number of configurations and the possible guiding configurations makes a total of over 300 possible combinations. The room parameters were factored into the calculations so that the user’s space, walls, and ceiling would not be encroached on by the wall during the motions.

The results were quite interesting. Some of the reference configurations worked considerably better than others. Figures 17 through 19 show a side view of the wall. The guide configuration is represented by a blue line. The green lines depict the path taken by the robot and grow lighter as time passes. The red line is the desired mode. In the algorithm, the tip is moving from its current location linearly toward its ending location. The motion of the interior links is based upon the guiding configuration, the current mode and the desired mode. In the beginning of the movement, the guide configuration has more influence on where the joint will move than the desired configuration. The following three figures are one example of how moving from one configuration to another can be changed through the use of guide configurations.

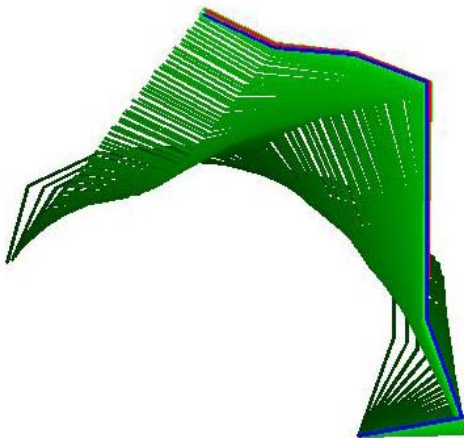

Figure 17: Composing mode to presenting mode guided by the presenting mode

Figure 17 is a depiction of no guiding configuration. One is being used, but it is the same as the ending configuration which negates having one. The robot does not move the top motors to relieve the bottom motors of high torque loads.

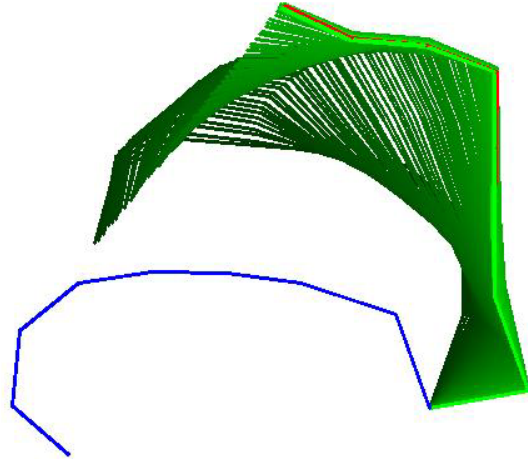

Figure 18: Composing to presenting mode guided by the gaming mode

As can be seen in figure 18, the guiding configuration allowed the top and middle joints to move into position and slowly allowed the base motors to move. This reduced the amount of torque the bottom motors had to overcome with their rotation. Figure 19 shows the effect of a less desirable guidance configuration. It has excess motion in the bottom two motors. The top joints take longer to move putting more torque on the bottom motors.

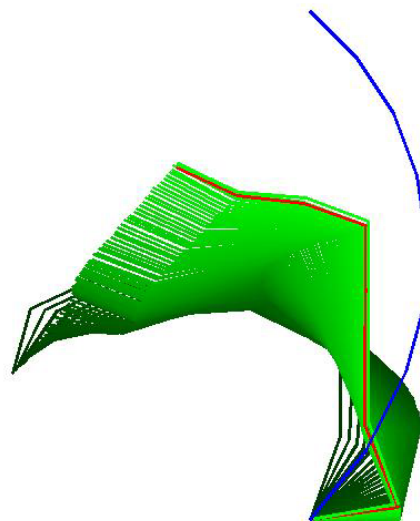

Figure 19: Composing mode to presenting mode guided by the football inspired mode

5 Conclusions

The novel robot “wall” surface presented in this paper

forms part of AWE, a novel “Animated Work Environment”, aimed at introduction of robotics at the architectural scale. The research is focused particularly on intelligent work environments, and as such the wall element of AWE forms part of an adaptable workstation. The robot wall, featuring a multiple folding panel structure, must adapt its configuration in real time to the changing needs and moods of the occupants of its environment. We have described the overall AWE concept and detailed the design and construction of the robot wall surface. Motion planning and control issues have been discussed. Simulation results demonstrate the effectiveness of the approach selected.

Ongoing work focuses on equipping the panels of the AWE wall with embedded IT elements. Formal usability testing has been conducted to simulate tax preparation using this prototype. Current testing is being done with an architectural design task. The information gathered will be used to refine the current system towards the end of 2007.

Acknowledgements

The authors acknowledge support from the U.S. National Science Foundation under grant number IIS-0534423.

References

- [1] Baecker, R. (Ed.), *Readings in groupware and computer-supported cooperative work*. San Mateo: Morgan Kaufmann, (1993).
- [2] Daniels, R. and Gugerty, L. Task Analysis of Information Flow for Teachers, Accountants, and Architects. Poster presented at the *American Psychological Association 115th Annual Convention*, San Francisco, CA, August 2007, in press.
- [3] EPFL Biologically Inspired Robotics Group, <http://birg.epfl.ch/page65721.html> [on-line].
- [4] Green, K. E., Gugerty, L., Walker, I. D., and Witte., J. Three robot-rooms/the AWE project, in: *Work in Progress, CHI 2006*, ACM Press (2006). Also: www.aweproject.org [on-line].
- [5] K. E. Green, L. J. Gugerty, J. C. Witte, I. D. Walker, H. Houayek, J. Rubinstein, R. Daniels, J. Turchi, M. Kwoka, I. Dunlop, and J. Johnson From Ethnography to Design (and back): Configuring and “Animated Work Environment” for Digital Lifestyles Submitted to: IE 2008
- [6] Johanson, B., Fox, A., and Winograd, T. The Interactive Workspaces Project: Experiences with Ubiquitous Computing Rooms, in: *IEEE Pervasive Computing* vol. 1, issue 2 (April/June, 2002).
- [7] Johnson, J. Kwoka, M., Houayek, H., Walker, I.D., and Green, K.E. Design, Construction, and Testing of a Novel Robotic Workstation, to appear, *Fourth International Conference on Computational Intelligence, Robotics, and Autonomous Systems (CIRAS)*, Palmerston North, New Zealand, November 2007.
- [8] Luff, P., Heath, C., Kazuoka, H., Yamakazi, K., and Yamashita, J. Handling documents and discriminating objects in hybrid spaces, in: Paper, *CHI 2006*, ACM Press (2006).
- [9] Mitchell, W.J. *e-topia*, Cambridge, MA 2000.
- [10] D.N. Nenchev, Redundancy Resolution through Local Optimization: A Review, *Journal of Robotic Systems*, Vol. 6, No. 6, 1989, pp. 769-798.
- [11] Oosterhuis, K. *Hyperbodies: Towards an E-motive Architecture*, Basel 2003.
- [12] Raskar, R., Welch, G., Cutts, M., Lake, A., Stesin, L., and Fuchs, H. The office of the future: a unified approach to image-based modeling and spatially immersive displays, in: Proc. *SIGGRAPH 98* (1998).
- [13] B. Siciliano, Kinematic Control of Redundant Robot Manipulators: A Tutorial, *Journal of Intelligent and Robotic Systems*, Vol. 3, 1990, pp. 201-212.
- [14] Streit, N., Rexroth, A., Holmer, T. Does “roomware” matter? Investigating the role of personal and public information devices and their combination in meeting room collaboration, in: Proc. *E-CSCW 97* (1997).
- [15] Streit, N. A., Tandler, P., Müller-Tomfelde, C., and Konomi, S. Roomware: Toward the Next Generation of Human-Computer Interaction Based on an Integrated Design of Real and Virtual Worlds, in: J. Carroll (ed.): *Human-Computer Interaction in the New Millennium*, Addison-Wesley (2001).
- [16] Wigdor, D., Shen, C., Forlines, C. and Balakrishnan, R. Effects of display position and control space orientation on user preference and performance, in: Paper, *CHI 2006*, ACM Press (2006).
- [17] Witte, J. C., and Turchi, J. Changing Patterns of Information and Communication Technology Use. In the Proceedings of the *Southern Sociological Society meeting*, Atlanta, Georgia, April 2007.
- [18] T. Yoshikawa, Analysis and Control of Robot Manipulators with Redundancy”, in *Robotics Research: The First International Symposium*, MIT Press, 1984, pp. 735-748.